

# Model CP201

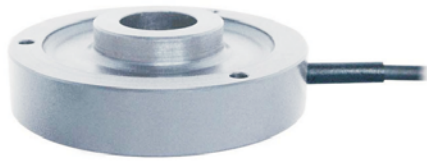

- Capacity: 30 kg...500kg
- Material: aluminum alloy
- Protection class: IP66
- Application: hopper sacles and other weighing devices.

## Performance Specifications

Parameter	Value	Units
Capacity	30, 50, 100, 500	kg
Rated Sensitivity	1.5±0.1	mV/V
Accuracy Class	C2	
Combined Error	±0.03	%FS
Temp. Coeff - Zero	±0.030	%FS/10°C
Temp. Coeff - Span	±0.017	%FS/10°C
Creep(30min.)	±0.024	%FS
Zero Balance	1.0	%FS
Input Resistance	770±10	Ω
Output Resistance	700±7	Ω
Insulation Resistance	≥5000	MΩ@50Vdc
Operating Temperature Range	-20 to +55	°C
Compensated Temperature Range	-10 to +40	°C
Excitation Voltage	5 to 12	Vdc
Safe Overload	120	%FS
Ultimate Overload	150	%FS
Body Material	aluminum alloy	mm
Environment Protection	IP66	
Cable Specification	Ø4.2mm cable, L=3m	

## Dimensions (in mm)

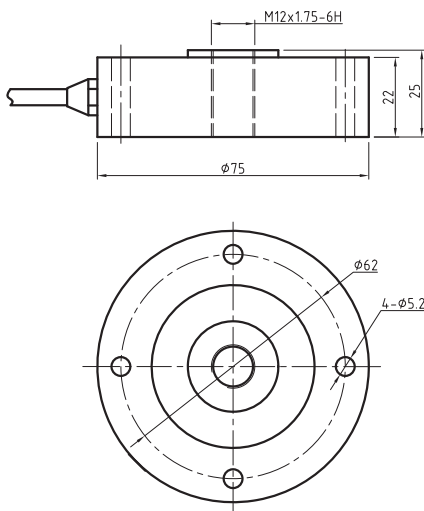

## Electrical Connection

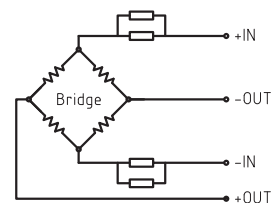

## Ordering Information

Model	Capacity	Sensitivity	Combined Error	Electrical interface	Customized Spec's
CP201	50kg	1.5mV/V	0.03%FS	Ø4.2mm cable, L=3m	